



 **EUROMOLD**

INTERFACE E

**Medium Voltage
Separable Connectors**

Catalogue 2026

NEXANS

POWER ACCESSORIES

An essential link in energy systems

The future will be electric. The present already is. As electrification gathers paces, network operators are undertaking large-scale projects to extend and modernize the grids. These projects require a wide range of power accessories. Nexans is a leading manufacturer and distributor in this field since more than 60 years, supplying a full range of power accessories to our global customers in about 100 countries.

We connect all types of cables, for Low High and Medium Voltage installations, and all types of conductors with any cross-section. We provide underground cable junctions, and connect cables to various types of equipment, including transformers and switchgear. Our products are used on both onshore and offshore

networks, on wind and solar farms, or in data centers for example.

Our range of products includes EUROMOLD® connectors, our cutting-edge EPDM technology, known for its exceptional performance and reliability. We also provide Cold- and Heat-Shrinkable joints and terminations, developed to be always easier to install and reliable. We pre-assemble ready to install jumpers. And our extensive range of GPH® ferrules and lugs, designed to meet the highest standards of quality and durability, are embodied in all our accessories kits or delivered separately.

Nexans is committed to delivering innovative solutions and top-notch products in the field of electrical connections and accessories.

Together, we have the power to electrify the future!

Laboratory accreditation

Since June 2000, Nexans independent ELAB laboratory obtained the BELAC accreditation no.144-TEST conform with the European standards for laboratories ISO 17025 for electrical testing of low and medium voltage cable accessories according to the international standards EN 50393, IEC 60502-4, IEC 61442 and HD 629.

ISO Certificate

Since 1992, Nexans commitment to quality and sustainable development is demonstrated by its ISO 9001 and ISO 14001 certifications.



At Nexans, we are proud of our manufacturing and kitting sites

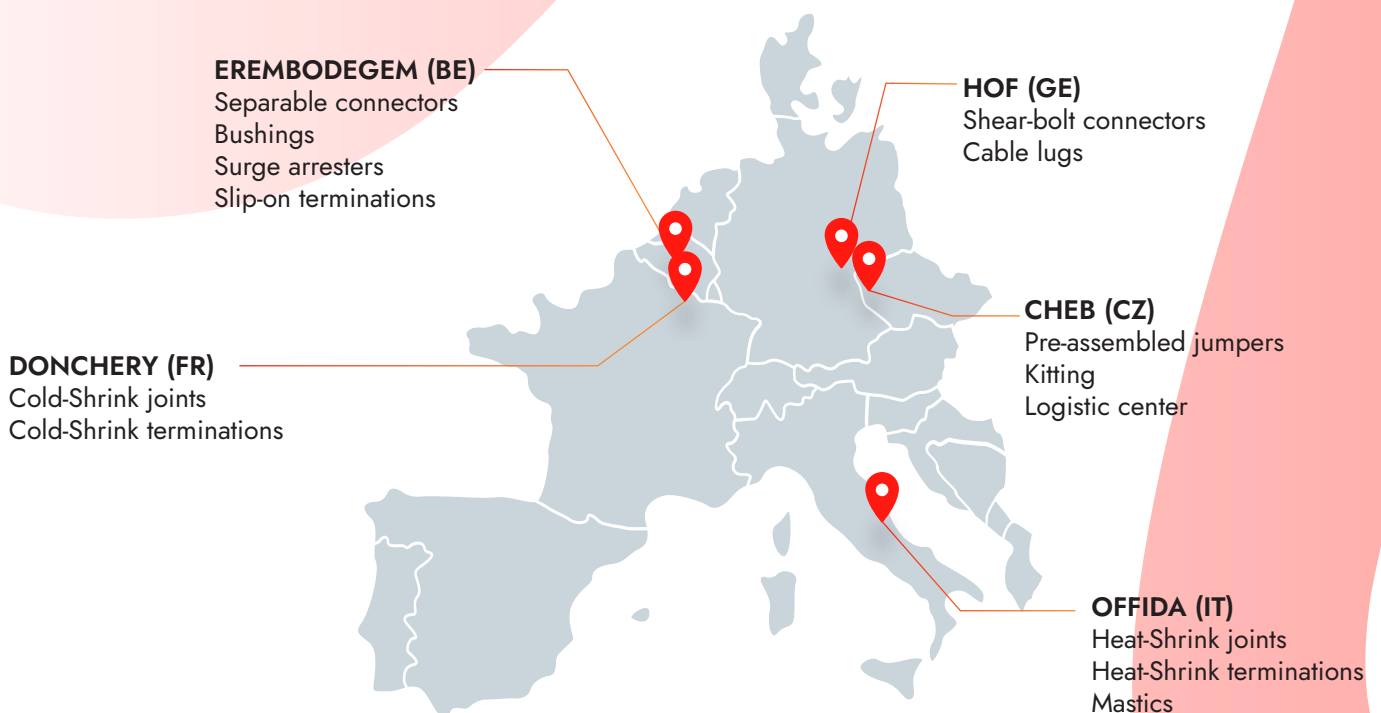

MEDIUM VOLTAGE SEPARABLE CONNECTORS



- Produced in **Europe**
- 100% routine tested
- Only **high-quality material** is used
- Made **100% of EPDM** rubber
- All connectors are tested conform to the **CENELEC HD629.1 standard**. Test reports available upon demand
- Degree of protection **IP67**: dust tight & immersion in water

- A complete range (12 kV - 42 kV)
- For cross sections from **16 mm² to 1200 mm²**
- Temperature range from **-60 °C to +130 °C**
- A range of associated coupling connectors and surge arresters all with compact design
- Maintenance free after correct installation.



Made in Europe since 50 years

EUROMOLD separable connectors are made in Europe using only high-quality material such as EPDM rubber. Each product is tested according to CENELEC standards to ensure long-lasting quality.

Compact & flexible design



The compact design of separable connectors uses less raw material and limits sub packaging. It also facilitates installation in reduced space equipment configuration. The ability to combine connectors for most interfaces offers flexibility in the design of your installation.



Reliable



EUROMOLD connectors have a proven track record of high reliability and performance in medium & low high voltage applications. Each separable connector is made with high quality components in Europe and individually tested before leaving the plant, ensuring a reliable connection.

Easy to install & safe



Make your job easier with Nexans separable connectors. When de-energized, they can easily and safely be installed & removed without specific tools. The high quality EPDM rubber outer jacket ensures a long-lasting protection even in harsh environmental conditions.

All-in-one solution



EUROMOLD's separable connectors are versatile, fitting to a variety of projects with their diverse shapes designed to accommodate a wide range of cross sections. It reduces complexity and minimizes stock requirements, offering solutions for interfaces ranging from A to F.



COMPACT SEPARABLE CONNECTORS

INTERFACE E - 5/8"

TABLE OF CONTENTS

784TB - tee connector
800PB-58 - coupling connector
804PB-58 - coupling connector
800SA-58 - surge arrester
Accessories
Possible arrangements

INTERFACE E - 5/8"

Dimensions according to IEEE std. 386 (in mm, except where noted).

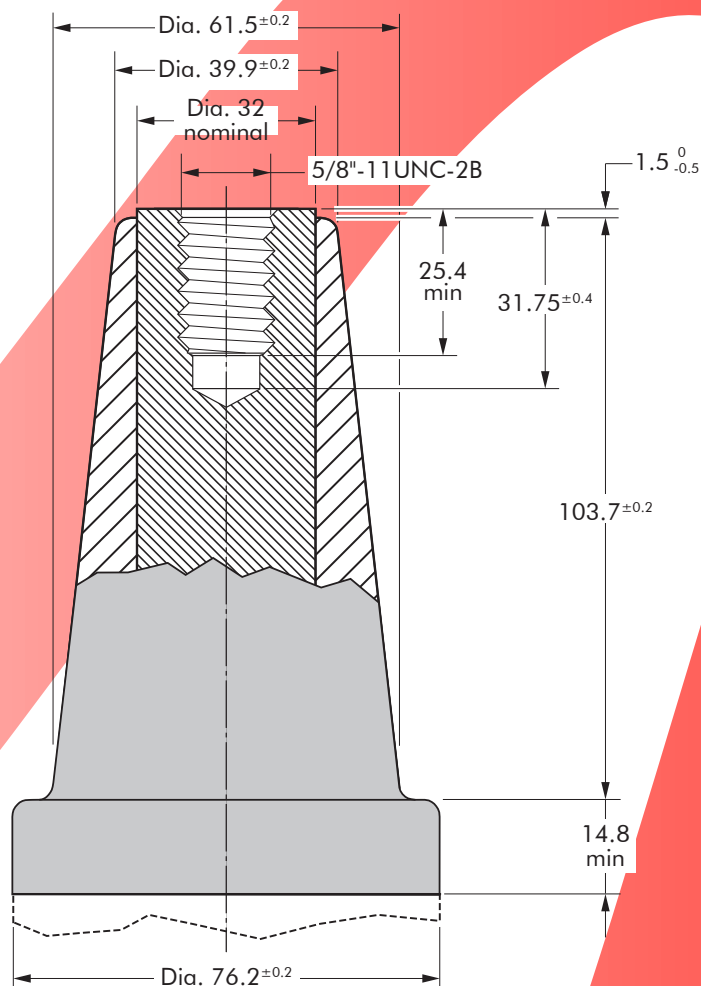

In mm.

While every care is taken to ensure that the information contained in this publication is correct, no legal responsibility can be accepted for any inaccuracy. Nexans Network Solutions N.V. - Div. Euromold reserves the right to alter or modify the characteristics of its products described in this catalogue as standards and technology evolve.

CONNECTING POSSIBILITIES

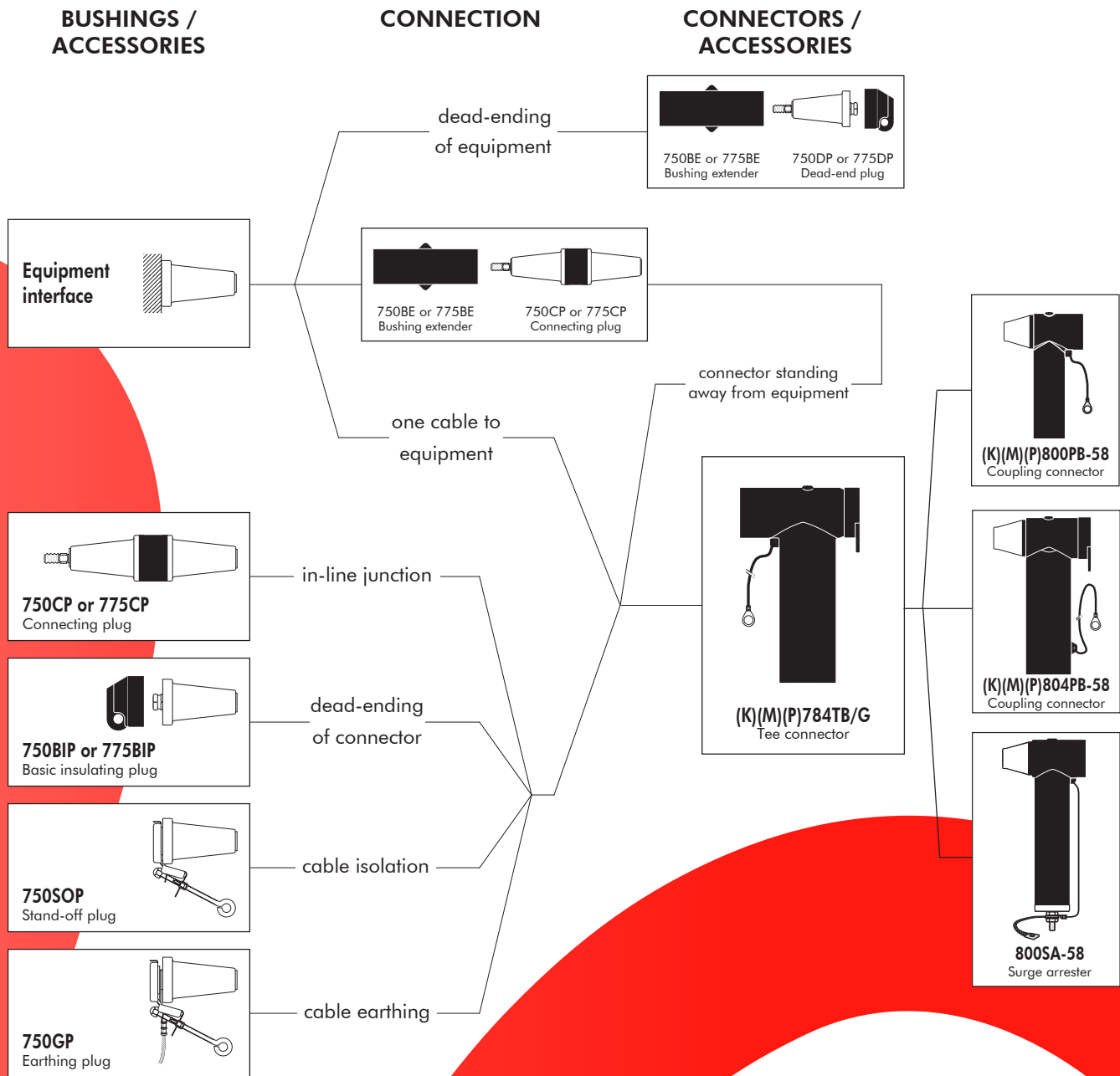

784TB

INTERFACE E - 5/8" TEE CONNECTOR

APPLICATION

Separable tee shape connector (bolted type) designed to connect polymeric insulated cable to equipment (transformers, switchgear, motors, ...). Also connects cable to cable when using the appropriate mating parts.

TECHNICAL CHARACTERISTICS

- The thick conductive EPDM jacket provides a total safe to touch screen.
- Each separable connector is tested for AC withstand and partial discharge prior to leaving the factory.



DESIGN

Separable connector comprising:

1. Conductive EPDM insert.
2. Conductive EPDM jacket.
3. Insulating EPDM layer moulded between the insert and the jacket.
4. Type E 5/8" interface as described by IEEE 386.
5. Conductor contact.
6. Basic insulating plug 858 BIPA (with VD point).
7. Cable reducer.
8. Conductive rubber cap.
9. Stud+flange nut 5/8".
10. Earthing lead.

The screen break design enables cable outer sheath testing without removing or dismantling the connector.

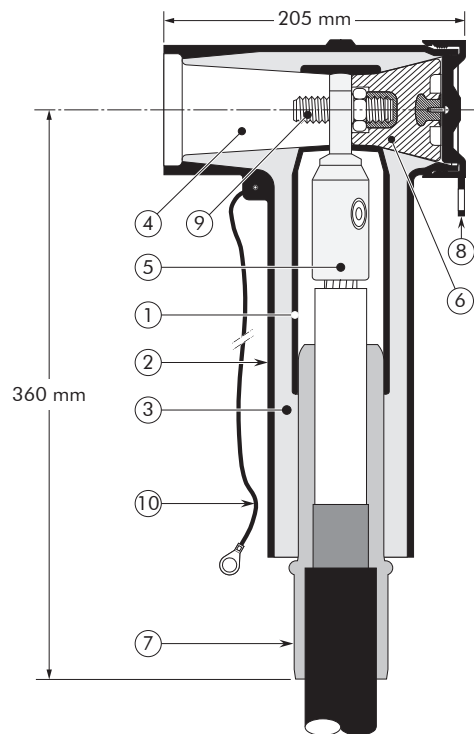

6/10 (12) kV
 6.35/11 (12) kV
 8.7/15 (17.5) kV
 12/20 (24) kV
 12.7/22 (24) kV
 18/30 (36) kV
 19/33 (36) kV
 20.8/36 (42) kV

Up to 42 kV
 Up to 1250 A

EUROMOLD

SPECIFICATIONS AND STANDARDS

The 784TB separable connector meets the requirements of CENELEC HD 629.1.

Separable connector type	Voltage U_m (kV)	Current I_r (A) When installed on an appropriate equipment bushing	Conductor sizes (mm ²)	
			min	max
784TB/G	12	1250	50	630
K784TB/G	24	1250	35	630
M784TB/G	36	1250	35	630
P784TB/G	42	1250	35	630

KIT CONTENTS

The complete (K)(M)(P)784TB/G tee connector kit comprises 3x the following components:

The kit also comprises silicone grease, gloves, wipers, roll adhesive tape, installation instructions and venting rod.

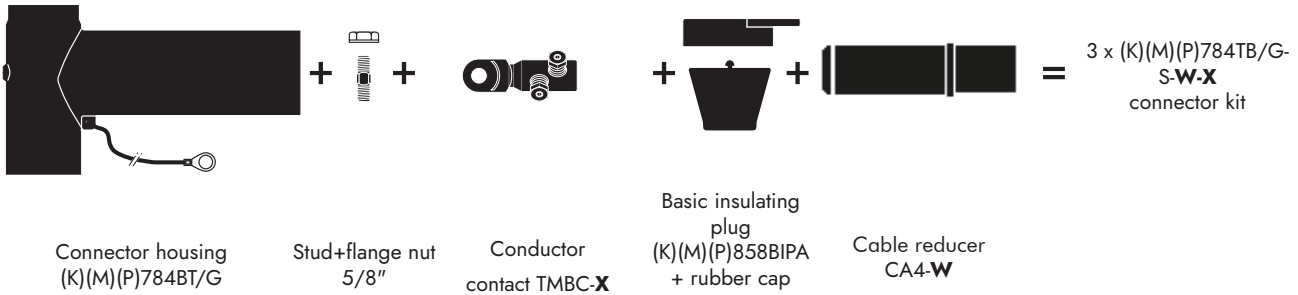

ORDERING INSTRUCTIONS

To order the tee connector, select the ordering part number which gives you the best centring of your core insulation diameter and substitute **X** using table X, according to your conductor size and type.

Add a 'K' for use up to 24 kV, add an 'M' for use up to 36 kV, add a 'P' for use up to 42 kV.

EXAMPLE:

The copper wire screened cable is 36 kV, 240 mm² stranded aluminium with a diameter over core insulation of 37.0 mm.

Order 3 x M784TB/G-S-4-32-95.300UN5

TABLE W

Ordering part number	Dia. over core insulation (mm)	
	min	max
3 x 784TB/G-S-4-15-X	16.0	22.0
3 x 784TB/G-S-4-19-X	20.0	26.5
3 x 784TB/G-S-4-22-X	23.5	31.0
3 x 784TB/G-S-4-27-X	28.5	37.5
3 x 784TB/G-S-4-32-X	34.0	42.5
3 x 784TB/G-S-4-37-X	39.0	48.5
3 x 784TB/G-S-4-41-X	43.5	55.0

TABLE X

Conductor sizes (mm ²)	Aluminium and copper conductor	
	Bolted	
35	16.95UN5	95.300UN5
50		
70		
95		
120	400.630UN5	
150		
185		
240		
300		
400		
500		
630		

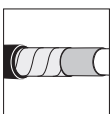

For use with copper tape screened cables. Order: Kit MT.



For use with other cable types. Please contact our representative.



For applications outdoors and in humid climate. Order: +MWS.



For use in potentially explosive atmospheres (for 12 kV max). Order: ATEX-IECEx



Components can be ordered individually.

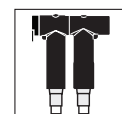

Multiple cable arrangement possible. Please contact our representative.

800PB-58

INTERFACE E - 5/8" COUPLING CONNECTOR FOR 784TB/G

APPLICATION

Separable coupling connector (bolted type) for dual cable arrangement. It has been designed to be used with 784TB separable tee connector.

TECHNICAL CHARACTERISTICS

- A thick conductive EPDM jacket provides a total safe to touch screen.
- Each separable connector is tested for AC withstand and partial discharge prior to leaving the factory.



DESIGN

1. Interface designed to fit 784TB connector.
2. Contact rod type 5/8".
3. Conductor connector.
4. Conductive EPDM insert.
5. Conductive EPDM jacket.
6. Insulating EPDM layer moulded between the insert and the jacket.
7. Cable reducer.
8. Conductive EPDM cap.
9. Basic insulating plug 858BIPA (with VD point).
10. Earthing lead.

The screen break design enables cable outer sheath testing without removing or dismantling the connector.

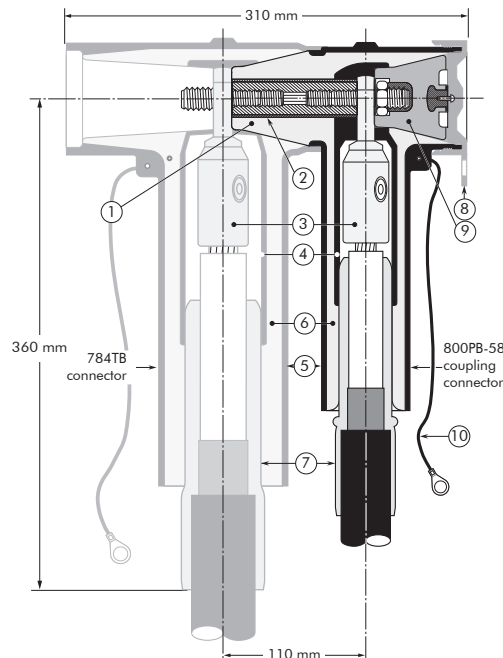

6/10 (12) kV
6.35/11 (12) kV
8.7/15 (17.5) kV
12/20 (24) kV
12.7/22 (24) kV
18/30 (36) kV
19/33 (36) kV
20.8/36 (42) kV

Up to 42 kV
1250 A

EUROMOLD

SPECIFICATIONS AND STANDARDS

The 800PB-58 coupling connector meets the requirements of CENELEC HD 629.1.

Separable connector type	Voltage U_m (kV)	Current I_r (A)	Conductor sizes	
			min	max
800PB/G-58	12	1250	16	300
K800PB/G-58	24	1250	16	300
M800PB/G-58	36	1250	35	240
P800PB/G-58	42	1250	35	240

KIT CONTENTS

The complete (K)(M)(P)800PB-58/G coupling connector kit comprises 3 x the following components:

The kit also comprises silicone grease, installation cone, gloves, wipers, roll adhesive tape and installation instructions.

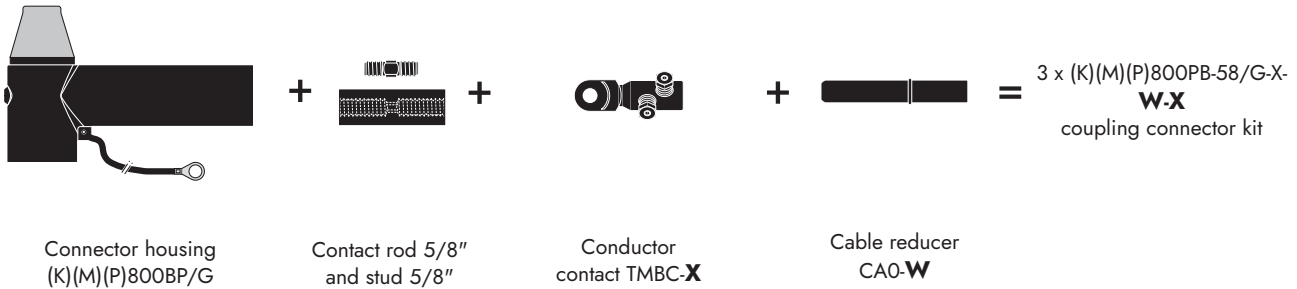

ORDERING INSTRUCTIONS

To order the coupling connector, select the ordering part number which gives you the best centring of your core insulation diameter and substitute **X** using table X, according to your conductor size and type. Add a 'K' for use up to 24 kV, add an 'M' for use up to 36 kV, add a 'P' for use up to 42 kV.

TABLE W

Ordering part number	Dia. over core insulation (inches)	
	min	max
3 x 800PB/G-58-011-X	12.0	19.0
3 x 800PB/G-58-015-X	16.0	26.5
3 x 800PB/G-58-018-X	19.0	32.6
3 x 800PB/G-58-021-X	22.0	34.6
3 x 800PB/G-58-027-X	28.5	37.5

EXAMPLE:

The cable is 24 kV, 185 mm² compact stranded copper with a diameter over core insulation of 27.5 mm.
Order 3 x K800PB/G-58-018-95.300UN5 coupling connector kit.

TABLE X

Conductor sizes (mm ²)	Aluminium and copper conductor	
	Bolted	
16	16.95UN5	
25		
35		
50		
70		
95	95.300UN5	
120		
150		
185		
240		
300		

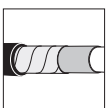

For use with copper tape screened cables.
Order: Kit MT.

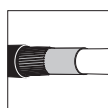

For use with copper wire screened cables.
No earthing device is necessary.



For use with other cable types.
Please contact our representative.



For outdoor applications.
Order: +MWS.



For use in potentially explosive atmospheres (for 12 kV max).
Add -ATEX to part number.

804PB-58

INTERFACE E - 5/8" COUPLING CONNECTOR FOR 784TB/G

APPLICATION

Separable coupling connector for dual cable arrangement. It has been designed to be used with 784TB separable tee connectors.

TECHNICAL CHARACTERISTICS

- A thick conductive EPDM jacket provides a total safe to touch screen.
- Each separable connector is tested for AC withstand and partial discharge prior to leaving the factory.



DESIGN

1. Interface designed to fit 784TB connector.
2. Contact rod type 5/8".
3. Conductor connector (hexagonal crimping, deep indent crimping or bolted).
4. Conductive EPDM insert.
5. Conductive EPDM jacket.
6. Insulating EPDM layer moulded between the insert and the jacket.
7. Cable reducer.
8. Conductive EPDM cap.
9. Basic insulating plug 858BIPA (with VD point).
10. Earthing lead.

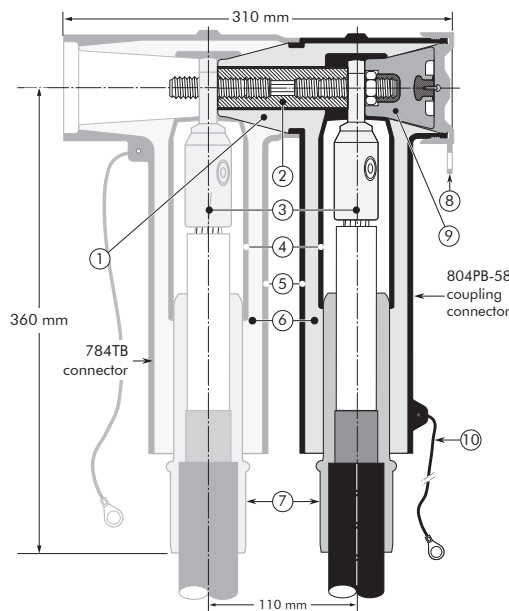

6/10 (12) kV
6.35/11 (12) kV
8.7/15 (17.5) kV
12/20 (24) kV
12.7/22 (24) kV
18/30 (36) kV
19/33 (36) kV
20.8/36 (42) kV

Up to 42 kV
1250 A

EUROMOLD

The screen break design enables cable outer sheath testing without removing or dismantling the connector.

SPECIFICATIONS AND STANDARDS

The 804PB-58 coupling connector meets the requirements of CENELEC HD 629.1.

Separable connector type	Voltage U_m (kV)	Current I_r (A)	Conductor sizes (mm ²)	
			min	max
804PB/G-58	12	1250	50	630
K804PB/G-58	24	1250	35	630
M804PB/G-58	36	1250	35	630
P804PB/G-58	42	1250	35	630

KIT CONTENTS

The complete (K)(M)(P)804PB/G-58 coupling connector kit comprises 3 x the following components:

The kit also comprises silicone grease, gloves, wipers, roll adhesive tape, installation instructions and crimp chart.

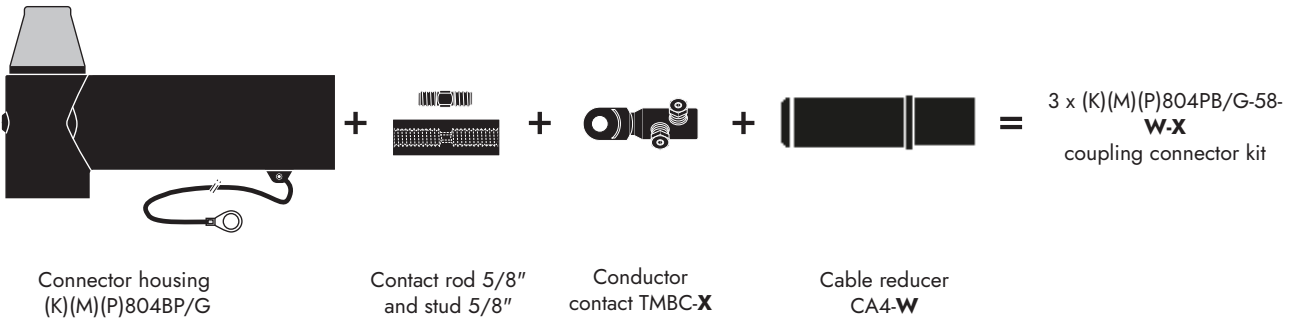

ORDERING INSTRUCTIONS

To order the coupling connector, select the ordering part number which gives you the best centring of your core insulation diameter and substitute **X** using table X, according to your conductor size and type.

Add a 'K' for use up to 24 kV, add an 'M' for use up to 36 kV, add a 'P' for use up to 42 kV.

Example:

The copper wire screened cable is 36 kV, 240 mm² stranded aluminium with a diameter over core insulation of 37.0 mm.

Order 3 x M804PB/G-58-4-32-185.400UN5 coupling connector kit.

TABLE W

Ordering part number	Dia. over core insulation (mm)	
	min	max
3 x 804PB/G-58-4-15-X	16.0	22.0
3 x 804PB/G-58-4-19-X	20.0	26.5
3 x 804PB/G-58-4-22-X	23.5	31.0
3 x 804PB/G-58-4-27-X	28.5	37.5
3 x 804PB/G-58-4-32-X	34.0	42.5
3 x 804PB/G-58-4-37-X	39.0	48.5
3 x 804PB/G-58-4-41-X	43.5	55.0

TABLE X

Conductor sizes (mm ²)	Aluminium and copper conductor	
	Bolted	
240	185.400UN5	
300		
400		
500		400.630UN5
630		

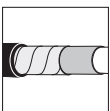

For use with copper tape screened cables.
Order: Kit MT.

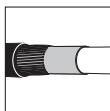

For use with copper wire screened cables.
No earthing device is necessary.



For use with other cable types.
Please contact our representative.



For applications outdoors and in humid climate.
Order: +MWS.



Components can be ordered individually.



For use in potentially explosive atmospheres (for 12 kV max).
Add -ATEX to part number.

800SA-58

INTERFACE E - 5/8" SURGE ARRESTOR FOR 784TB/G

APPLICATION

Surge arrester designed to protect 12, 24, 36 and 42 kV class components, including transformers, equipment, cable and accessories from high voltage surges resulting from lightning or switching. It has been designed to be used with the 784TB separable tee connectors.

TECHNICAL CHARACTERISTICS

- This surge arrester is a metal oxide varistor surge arrester in an elbow configuration.
- Each arrester is tested for AC withstand, partial discharge and critical voltage prior to leaving the factory.



DESIGN

Surge arrester comprising:

1. Interface designed to fit the 784TB tee connector.
2. Conductive EPDM insert.
3. Conductive EPDM jacket.
4. Insulating EPDM layer moulded between the insert and the jacket.
5. Receptacle for contact rod.
6. Metal oxide valve elements.
7. Steel cap.
8. Earth connection.
9. Earth lead.

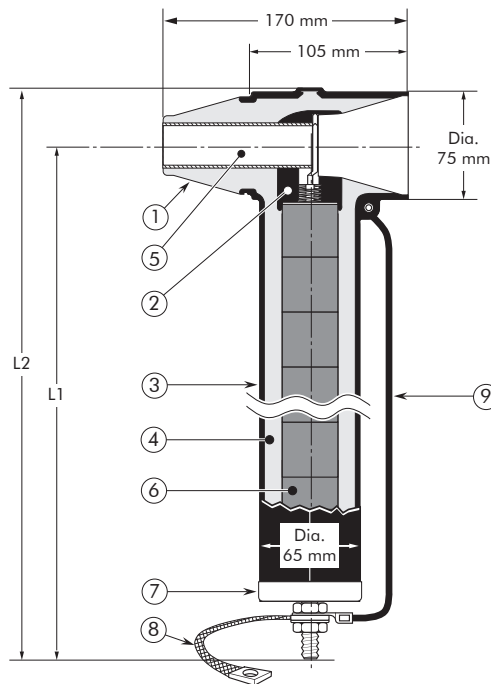

6/10 (12) kV
6.35/11 (12) kV
8.7/15 (17.5) kV
12/20 (24) kV
12.7/22 (24) kV
18/30 (36) kV
19/33 (36) kV
20.8/36 (42) kV

Up to 42 kV

EUROMOLD

SPECIFICATIONS AND STANDARDS

- The 800SA-58 surge arresters meet the test requirements of IEC 60099-4.
- Station class (SL); Qrs = 1.0 As
- Energy absorption 4.0 kJ/kV_{Ur}

Surge arrester type	Nominal discharge current I _n (kA)	Rated voltage U _r (kV)	Max. continuous operating voltage U _c (kV)	Dimensions (inches)	
				L1	L2
800SA-58-10-6N	10	6	4.8	10.63	12.20
800SA-58-10-9N	10	9	7.2	10.63	12.20
800SA-58-10-12N	10	12	9.6	10.63	12.20
800SA-58-10-15N	10	15	12.0	10.63	12.20
800SA-58-10-18N	10	18	14.4	10.63	12.20
800SA-58-10-22N	10	22	17.6	10.63	12.20
800SA-58-10-24N	10	24	19.2	14.57	16.14
800SA-58-10-27.5N	10	27.5	22.0	14.57	16.14
800SA-58-10-30N	10	30	24.0	14.57	16.14
800SA-58-10-33N	10	33	26.4	14.57	16.14
800SA-58-10-36N	10	36	28.8	14.57	16.14
800SA-58-10-42N	10	42	33.6	18.50	20.08
800SA-58-10-45N	10	45	36.0	18.50	20.08
800SA-58-10-51N	10	51	40.8	18.50	20.08

TYPICAL APPLICATION AND DIMENSIONS

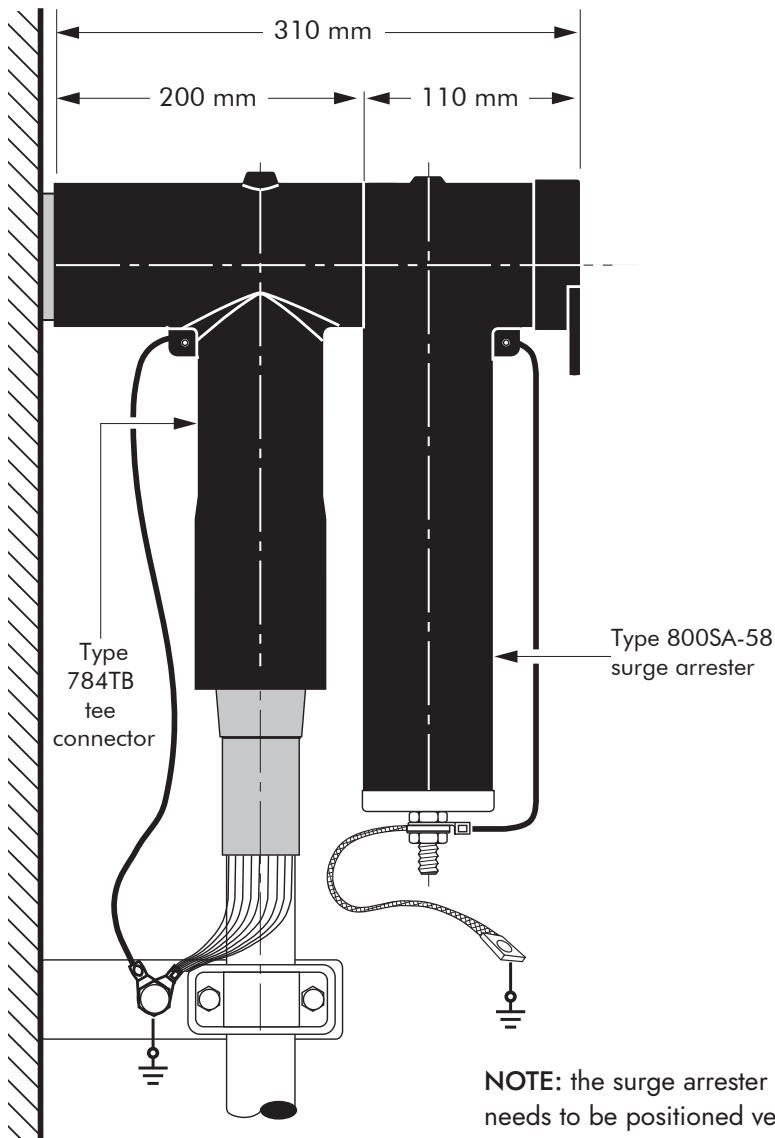

NOTE: the surge arrester body needs to be positioned vertically after installation.

ORDERING INSTRUCTIONS

To order the surge arrester, specify the surge arrester type, as described on previous page.

EXAMPLE:

For a maximum continuous operating voltage (r.m.s.) of 24 kV and a nominal discharge current of 10 kA.

Order a 800SA-58-10-30N surge arrester.



For use in potentially explosive atmospheres (for 12 kV max).
Add -ATEX to part number.

TECHNICAL DATA

Surge arrester type	Steep current residual voltage @ 10 kA [1/20 μs] (kV)	Lightning current residual voltage [8/20 μs] (kV)			Switching impulse residual voltage [36/90 μs] (kV)		High current impulse withstand (kA)
		@ 5 kA	@ 10 kA	@ 20 kA	@ 125 A	@ 500 A	
800SA-58-10-6N	18.5	16,2	17,2	19,3	12,6	13,2	100
800SA-58-10-9N	26.3	23	24,5	27,5	18,1	19,1	100
800SA-58-10-12N	36.3	31,5	33,6	37,1	25,1	26,5	100
800SA-58-10-15N	45.3	39,4	42	46,4	31,4	33,1	100
800SA-58-10-18N	54.4	47,3	50,4	56,4	37,7	39,7	100
800SA-58-10-22N	66.5	57,8	61,6	68,1	46	48,5	100
800SA-58-10-24N	72.5	63	67,2	75,2	50,2	53	100
800SA-58-10-27.5N	81.6	71	75,6	85	56,5	59,6	100
800SA-58-10-30N	90.7	78,8	84	94	62,8	66,2	100
800SA-58-10-33N	99.7	86,7	92,4	102,1	65	68,5	100
800SA-58-10-36N	108.8	94,5	100,8	112,7	75,3	79,4	100
800SA-58-10-40N	120.9	105,1	112	123,8	83,7	88,3	100
800SA-58-10-42N	126.9	110,3	117,6	130	87,9	92,7	100
800SA-58-10-45N	136	118,2	126	139,3	94,2	99,3	100
800SA-58-10-51N	154.1	134	142,8	160,4	106,7	112,5	100



ACCESSORIES

APPLICATION

For use with connectors and bushings with an INTERFACE E - 5/8" as described in IEEE std. 386.

TECHNICAL CHARACTERISTICS

All these products, except the earthing plug, are tested for AC withstand and partial discharge prior to leaving the factory.

6/10 (12) kV
6.35/11 (12) kV
8.7/15 (17.5) kV
12/20 (24) kV
12.7/22 (24) kV
18/30 (36) kV

Up to 36 kV

750CP & 775CP CONNECTING PLUG

For connecting two or more connectors with a type E - 5/8" interface together, thus creating a separable cable joint or a multiple cable connection to equipment.

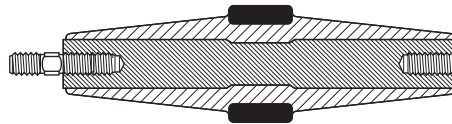

ORDERING INSTRUCTIONS

Order 750CP for 800 A or 775CP for 1250 A applications.

750BE & 775BE BUSHING EXTENDER

Provides an extension piece to allow cables to stand away from equipment. Is used in conjunction with the connecting plug (750CP or 775CP).

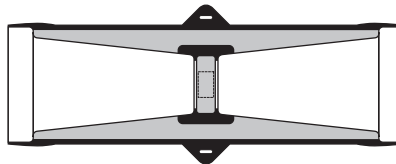

ORDERING INSTRUCTIONS

Order 750BE for 800 A or 775BE for 1250 A applications.

750SOP STAND-OFF PLUG

Is designed to support and 'dead-end' connectors with a type E - 5/8" interface when removed from equipment.

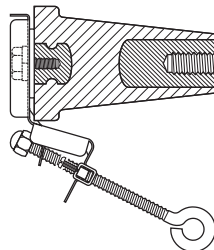

ORDERING INSTRUCTIONS

Order 750SOP for 800 A and 1250 A applications.

750GP EARTHING PLUG

Is designed to support and earth connectors with a type E - 5/8" interface when removed from equipment.

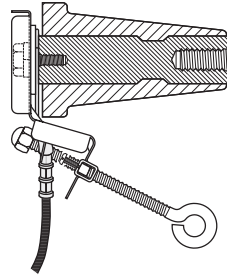

ORDERING INSTRUCTIONS

Order 750GP for 800 A and 1250 A applications.

POSSIBLE ARRANGEMENTS

784TB

Single cable arrangement.
 Order 784TB for 12 kV,
 K784TB for 24 kV,
 M784TB for 36 kV or
 P784TB for 42 kV applications.

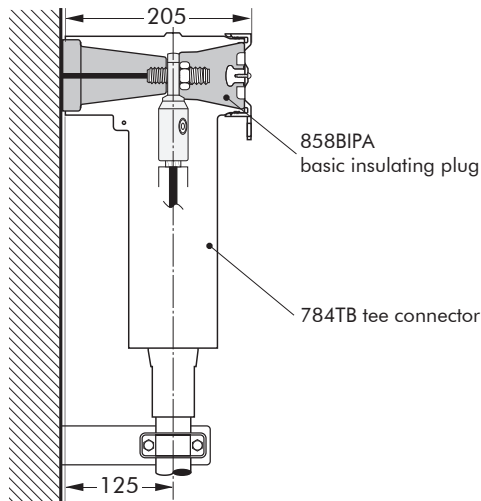

784TB+800PB-58

Dual cable arrangement.
 Order 784TB+800PB-58 for 12 kV,
 K784TB+K800PB-58 for 24 kV,
 M784TB+M800PB-58 for 36 kV
 or P784TB+P800PB-58 for 42 kV
 applications.

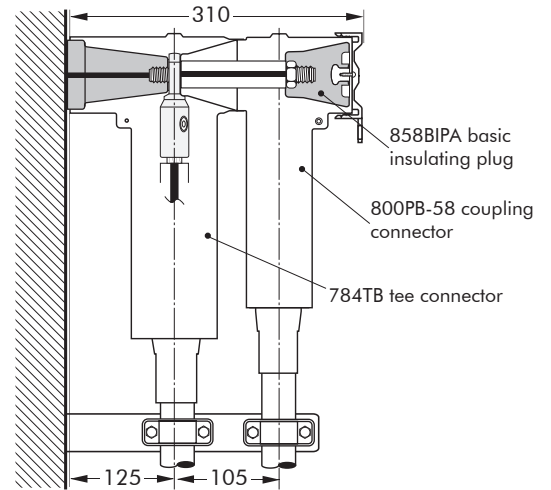

750BE+784TB

Connector standing away from
 equipment.
 Order 750BE+784TB for 12 kV,
 K750BE+K784TB for 24 kV or
 M750BE+M784TB for 36 kV
 applications.

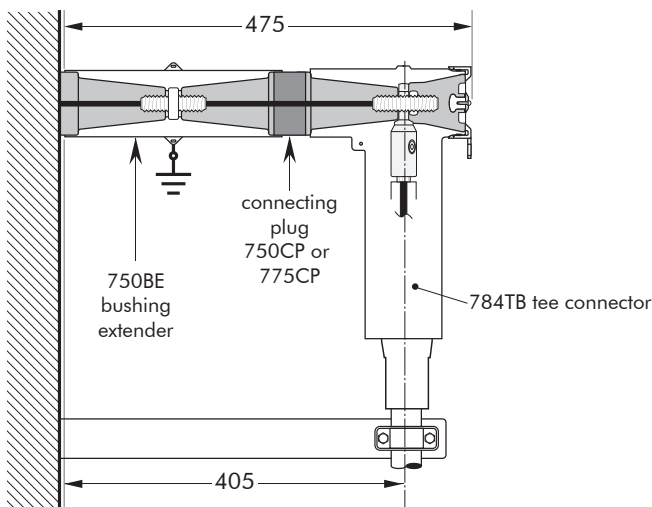

784TB+800SA-58

Single cable arrangement with surge
 arrester.
 Order 784TB+800SA-58 for 12 kV,
 K784TB+K800SA-58 for 24 kV,
 M784TB+M800SA-58 for 36 kV
 or P784TB+P800SA-58 for 42 kV
 applications.

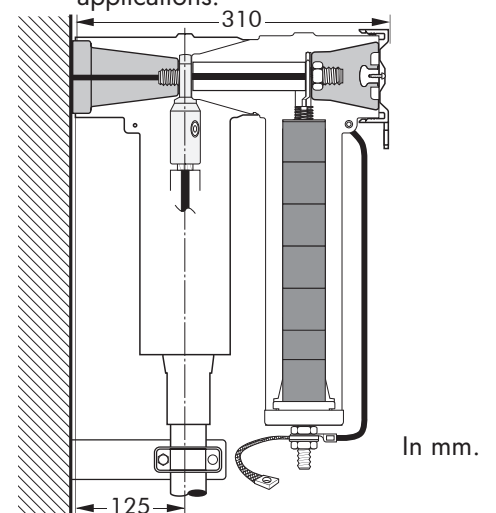

In mm.

CONNECTOR ON STAND-OFF PLUG

Order 750SOP for 12 kV, K750SOP for 24 kV or M750SOP for 36 kV applications.

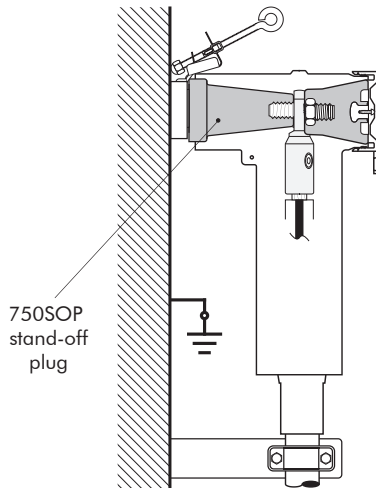

CONNECTOR ON EARTHING PLUG

Order 750GP for 12 kV, 24 kV or 36 kV applications.

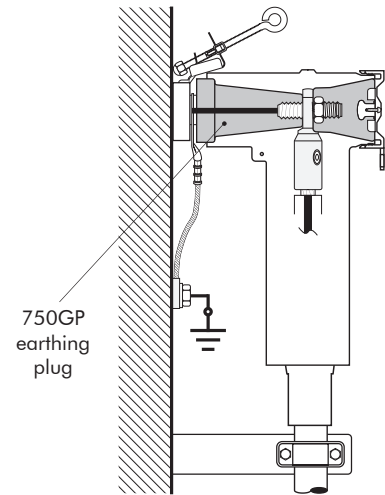

In mm.

About Nexans

For over a century, Nexans has played a crucial role in the electrification of the planet and is committed to electrifying the future. With approximately 28,500 people in 41 countries, the Group is paving the way to a new world of safe, sustainable and decarbonized electricity that is accessible to everyone. In 2023, Nexans generated 6.5 billion euros in standard sales. The Group is a leader in the design and manufacturing of cable systems and services across four main business areas: Power Generation & Transmission, Distribution, Usage and Industry & Solutions.

Nexans was the first company in its industry to create a Foundation supporting sustainable initiatives, bringing access to energy to disadvantaged communities worldwide. The Group is recognized on the CDP Climate Change A List as a global leader on climate action and has committed to Net-Zero emissions by 2050 aligned with the Science Based Targets initiative (SBTi).

Nexans. Electrify the future.

Nexans is listed on Euronext Paris, compartment A.

For more information, please visit www.nexans.com

—

Nexans Network Solutions NV - div. EUROMOLD

Nexans Network Solutions NV - div. EUROMOLD

Zuid III - Industrielaan 12

B-9320 EREMBODEGEM-AALST — BELGIUM

Tel: +32 (0)53/85 02 11

E-mail: sales.euromold@nexans.com

www.nexans.be/poweraccessories



Find out more about Nexans Power Accessories.